

Eirich mixer: The R12 series

Usable capacity of up to 500 liters
Highly efficient drives
Very easy to clean



The Pioneer in Material Processing®

The R12 series: Designed for a usable capacity of up to 500 liters

One machine – many possibilities

- For excellent preparation results in a wide range of consistencies
- For single batch or continuous operation
- With the globally recognized Eirich mixing system for consistent and reproducible quality of the mixed product



Plasticizing
- Kneading

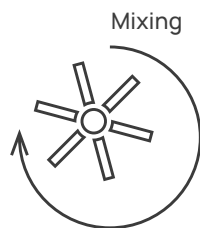

Mixing

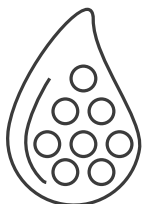

Dispersing

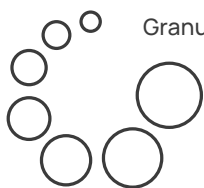

Granulating

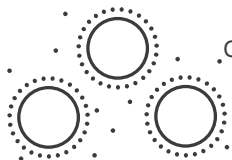

Coating

The Eirich mixing system

This special mixing system comprises just 3 components. These components can be adapted in a particularly flexible way to the specific requirements of the mixing processes.

1. The rotating mixing pan, which moves the mix into the path of the mixing tools.
2. One eccentrically arranged mixing tool; its design, direction, and speed can be perfectly tailored to the application in hand. In addition, a strong vertical component is introduced into the flow of the mix through suitable arrangement of the rotating mixing pan.
3. The bottom/wall scraper, which adds additional movement to the flow of the mix and prevents caking on the wall or bottom of the pan, as well as aiding the discharge of the mix at the end of the mixing cycle.



Available in three versions

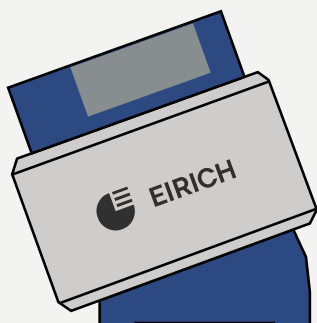

R12 The Allrounder

Usable capacity of up to 500 liters.
For mixing, granulating, plasticizing/kneading,
and coating.

Applications

**Concrete, refractory materials, ceramics,
foundries, fertilizers, and many more.**

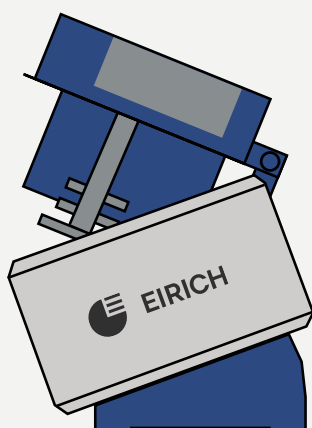

R12W The flexible one

With a hinged mixing pan cover. For simple and effi-
cient cleaning of the machine interior and tools.

Applications

**Lithium-ion compounds, fertilizers, welding
powder, graphite compounds, specialist concre-
te types, and many more.**

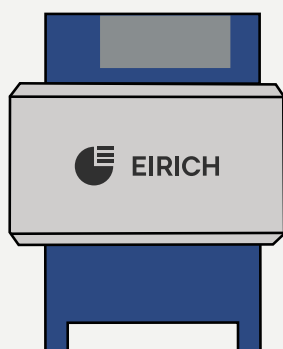

RLV12 The MixSolver®

The Eirich solution for dispersion and dissolving.
For cost-effective preparation of compounds that
are high in solid content, paste-like, or highly vi-
scous.

Applications

**Dispersing tasks, ceramic slips, electrode slur-
ry (batteries/energy storage devices), sealing
compounds, ready-to-use plaster, and many
more**

R12: The ultimate mixer series

Eirich makes the difference

Advantages

- Fast mixing times and highly homogeneous mixes
- 100% material agitation with every rotation of the mixing pan
- Hybrid mixing processes
Targeted control of energy input through adjustable drives for the rotor and mixing pan
- Cost-effective method of operation
- High efficiency of the mixing system means low energy consumption and minimal wear and tear
- Reliable reproducibility for product quality and batch times

- Robust design and construction guarantee excellent service life and high availability

Service and cleaning

- Easy accessibility for cleaning, inspection, and tool changes thanks to the large service doors
- Only 2 tools to clean
- Automatic cleaning device (TopClean) meets the highest cleaning demands – wet or dry (optional)
- Adjustable service positions for optimized access to the mixing pan

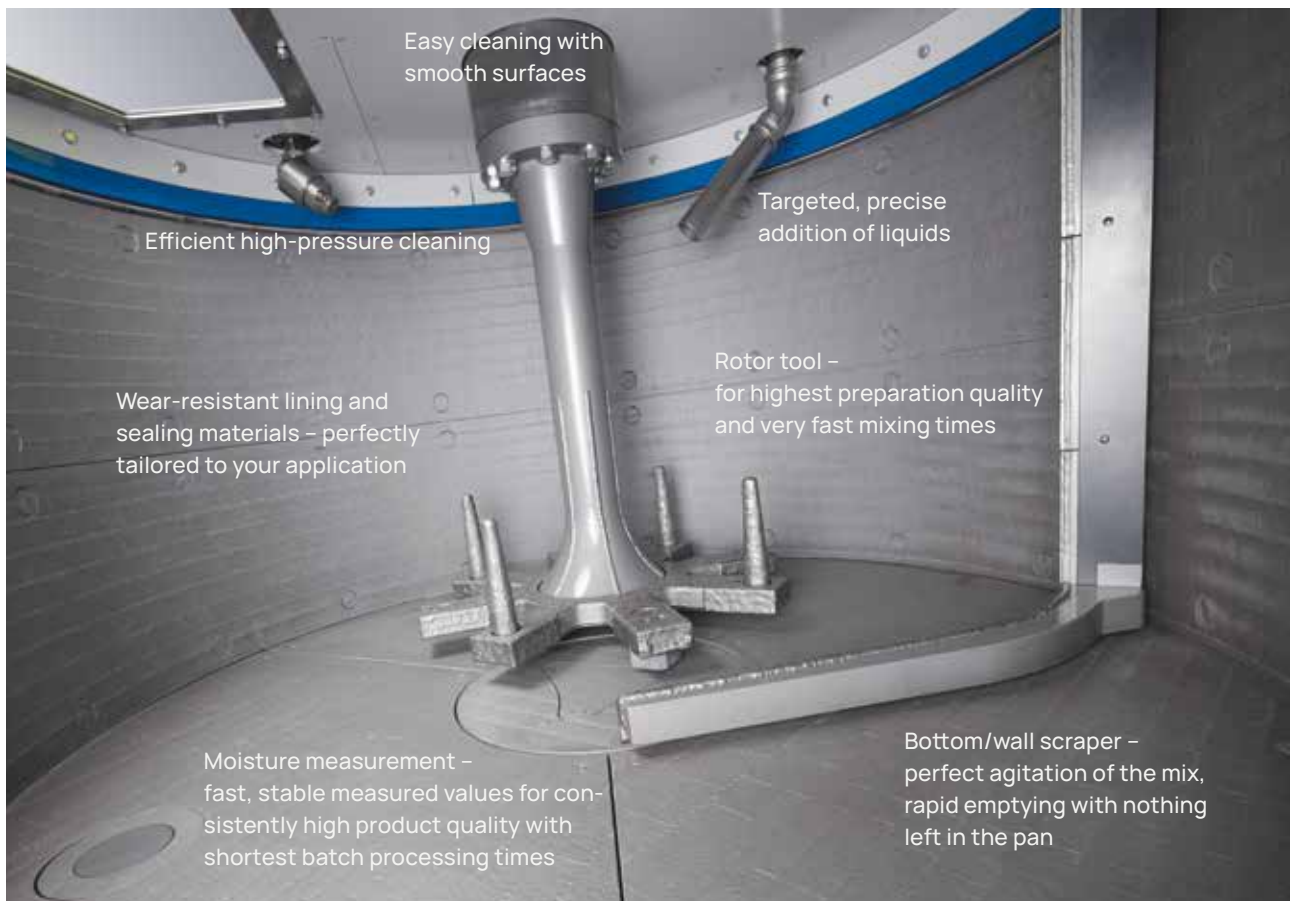

The inner workings of the Eirich mixer



RV12 mixer with optional equipment: HighTorqueDrive, high-pressure cleaning system, camera system

Highly efficient drives

- Overload capacity
- Energy efficient
- Low maintenance

Infeed

- Raw materials flow into the mixing pan freely via the large openings

Emptying

- Central emptying at the bottom

State-of-the-art control technology

- Single machine control
- Complete line control

Equipment options

- Moisture measuring equipment
- Temperature measurement
- Cleaning system (wet/dry)
- Systems for temperature control / heating of the material being mixed
- Camera system (LiveView)
- Non-stick coating
- Parts that come into contact with the mix can be made of stainless steel
- Seals and wear parts are also available made of polyurethane
- Vibration insulation
- Weighing equipment:
- and many more...

Digital solutions

- ProView
- MyEirich

R12W: with hinged cover

For applications with intensive cleaning requirements

Features

- Ideal for batchwise operation
- With all the same advantages and equipment options as the R12 mixer

Special advantages

Cover of the mixing pan can be lifted up hydraulically

- Enables fast and ergonomic access to the mixing tools and to the interior of the mixing pan
- Cleaning, inspections and tool changes can be carried out even more easily and effectively

W-type equipment options

- No product carryover – the mixer meets the highest demands for cleaning: mixing pan with no joints or gaps and all inside corners rounded off
- Effortless integration into a production line thanks to the partially fixed mixing pan cover



R12W mixer with closed mixing pan cover



Mixing pan with no joints or gaps



R12W mixer with open
mixing pan cover

RLV12: The MixSolver®

For dispersing and dissolving

Particularly well suited to cost-effective preparation of bodies with a high solids content, pasty bodies, or highly viscous bodies, such as slips and slurries

Features

- Mixer inclination 0°
- Available as a W-type with a hinged mixing pan cover
- Parts that come into contact with the mix are made of stainless steel
- Vacuum version (option)
- Double jacket mixing pan for heating and cooling (option)

Special closure systems

- Special attention is paid to the transfer of the processed material to the downstream peripherals
- For safe and clean emptying of pasty bodies and liquid compounds

- Optional: Suction systems are available for low-viscosity compounds

Special discharge area

- Perfectly suited to paste-like and highly viscous compounds
- Edgeless design with smooth surfaces prevents material adhesion and product carryover

Cleaning

- Large access doors for easy cleaning of the discharge area
- Option available depending on the raw materials processed:
Touching bottom/wall scraper
- Automated cleaning in combination with the high-pressure mixer cleaning system TopClean for high levels of cleanliness



Interior of the mixing pan
with mixing tool and touching bottom/wall scraper



External view:
Discharge area and transfer pipe



 EIRICH

MixSolver® as an RLV12W VAC version
for the preparation of lithium-ion electrode slurry

Accessibility: Fast and ergonomic



Large service doors for cleaning, inspection, and tool changes



Protected and easily accessible:
Central arrangement of drives,
units and valves

Thoughtfully integrated into your system.

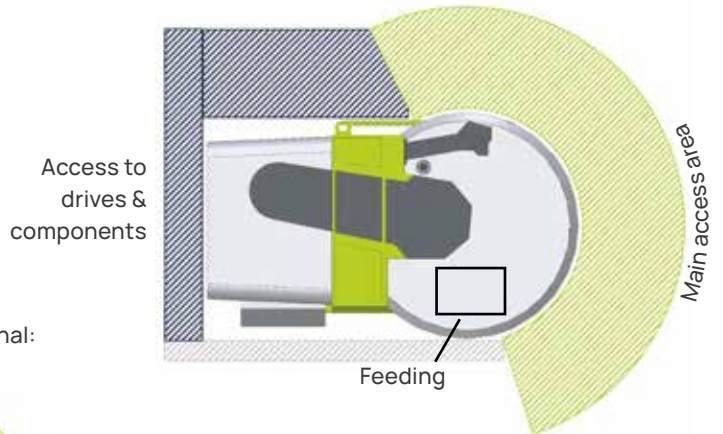
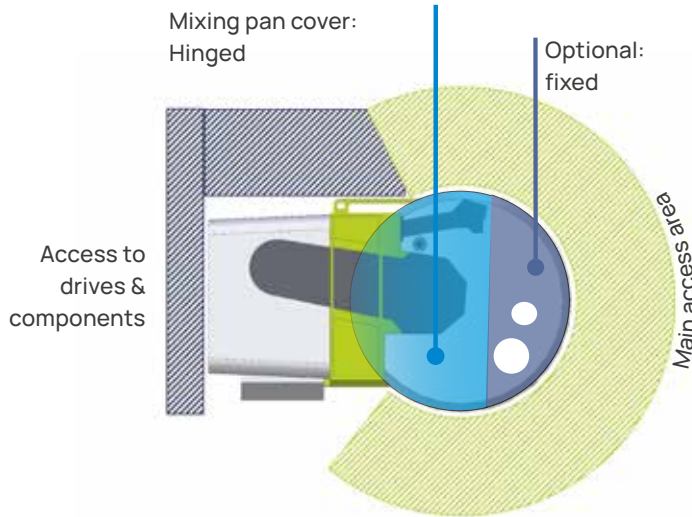

R12W, RV12W

Hinged mixing pan cover
Optional: With fixed part for infeed connections



RV12W: With partially fixed pan cover

RV12 mixer:
Optimum accessibility
in the final line

Technical data for your planning

Typ	Usable capacity*		Drives (kW)		Weight kg
	Liters	kg max.	Pan	Rotor	
R12 /R12W	250	400	7,5	11 - 45	3600
RV12 RV12W RLV12	500	800	7,5	22 - 75	4000

* depending on application

R12

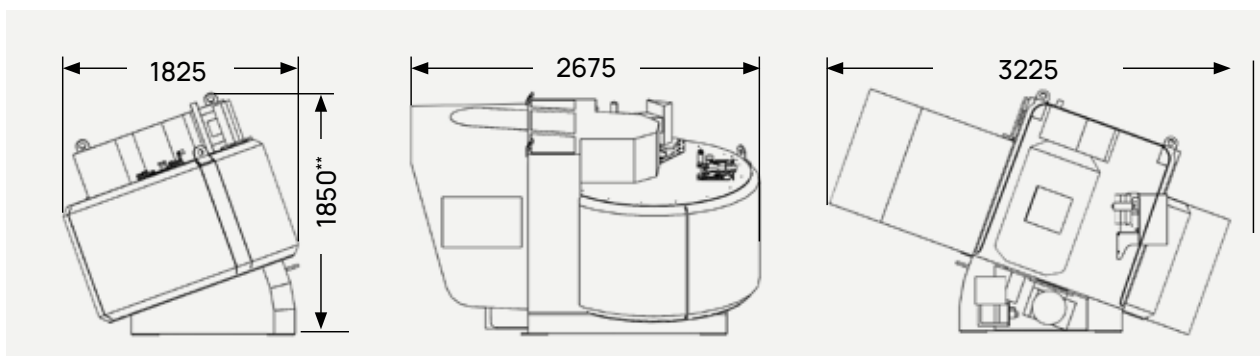

** V-belt drive, direct drive with HighTorqueDrive: 1950 mm

R12W

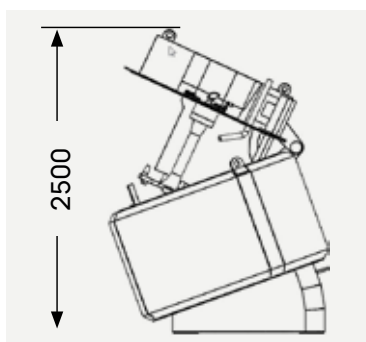

RLV12

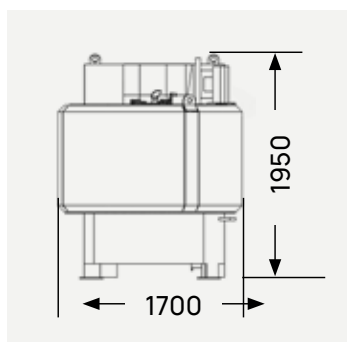

More information at:

www.eirich.com